

S250 ROCK DRILL

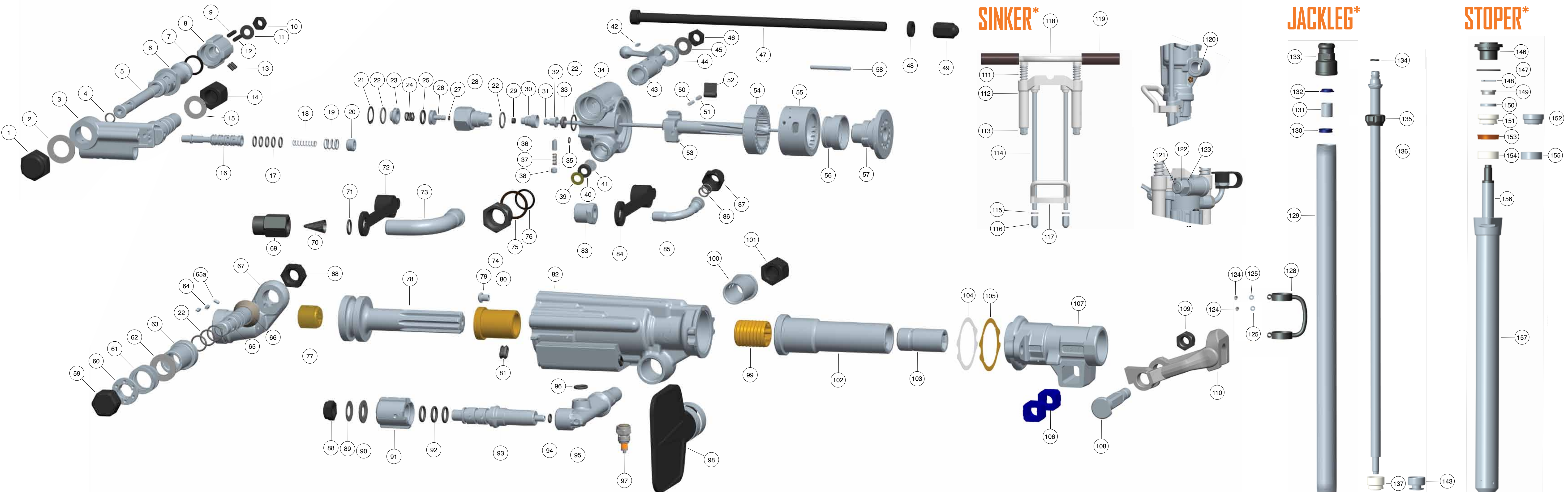

Item	Part Number	Description	Qty.
1	5608539	Operating handle nut	1
2	5601453	Washer, int. serrated	1
3	5602817	Adapter, handle tapered	1
4	5603224	O ring	8
5	5604922	Control spindle	1
6	5601922	Control body	1
7a	5602475	Friction ring black	1
7b	5602485	Friction ring green	1
8	5609262	Twist grip	1
9	5600522	Sel-loc pin inner	2
10	5605972	Spindle nut	1
11	5601562	Washer spring disc	1
12	5600822	Sel-loc pin outer	2
13	5600088	Sel-loc pin	2
14	5605652	Domed nut	1
15	5601442	Washer, ext. serrated	1
16	5608576	Valve ASM, retract (O rings included)	1
17	5603224	O ring	8
18	5605152	Retract valve spring	1
19	5605153	Valve sleeve spring	1
20	5605155	Plunger plug	1
21	5605529	Internal circlip	1
22	5600224	O ring	6
23	5602462	Spring cap	1
24	5607152	Spring	1
25	5601244	O ring	1
26	5604463	Water control valve	1
27	5603119	O ring	1
28	5602922	Water control valve body	1
29	5604872	Water valve seat	1
30	5605523	Water valve seat retainer	1

Item	Part Number	Description	Qty.
31	5604218	Water tube	1
32	5601864	Water tube spacer	1
33	5601866	Water tube seal	1
34a	5604430	Backhead, Jackleg	1
34b	5603885	Backhead, Stoper	1
35	5603122	O ring, Stoper	1
36	5604096	Throttle valve plunger	1
37	5602993	Throttle plunger spring	1
38	5602887	Plug, throttle detent	1
39	5603667	Thrust washer	1
40	5603545	Water inlet rubber	1
41	5604380	Water inlet screen	1
42	5602995	Throttle valve key	1
43a	5601667	Throttle valve Stoper	1
43b	5601665	Throttle valve Jackleg	1
44a	5601628	Handle, throttle Stoper	1
44b	5601633	Handle, throttle Jackleg	1
45	5601562	Washer, spring disc	1
46	5602997	Throttle valve nut	1
47a	5602105	Side rod, Stoper	2
47b	5601631	Side rod, Jackleg	2
48	5602027	Washer side rod nut	2
49a	5601900	Side rod nut open	2
49b	5601905	Side rod nut domed	2
50	5602272	Pawl spring	4
51a	5605422	Pawl plunger steel	4
51b	5604749	Pawl plunger plastic	4
52	5608827	Double sided pawl	4
53	5604616	Rifle bar	1
54	5601822	Ratchet ring	1
55	5600658	Valve box	1
56	5609572	Valve	1

Item	Part Number	Description	Qty.
57	5600558	Valve plug	1
58	5604747	Locating pin	1
59	5608449	Spindle seal	1
60	5601262	Spindle lock washer	1
61	5602862	Spring	1
62	5603144	Spindle thrust washer	1
63	5604362	Cylinder lug bush	1
64	5607352	Lock washer key	2
65	5603922	Clevis, body spindle (incl. 65a)	1
65a	5604938	Pin	1
66	5609042	Spindle cone	1
67	5601417	Clevis body	1
68	5603912	Clevis body spindle nut	1
69	5609708	Air filter assembly	1
70	5605079	Conical filter	1
71	5600253	O ring	1
72	5604625	Cap, air	1
73	5606362	Air bend	1
74	5606372	Air bend nut	1
75	5602172	Copper washer	1
76	5608233	O ring	1
77	5609162	Rifle nut	1
78	5605443	Piston S250	1
79a	5604012	Ferrule, Jackleg cylinder	1
79b	5602021	Plug, Stoper cylinder	1
80	5608252	Front cylinder liner	1
81a	5603889	Plug, muffled cylinder exhaust	4
81b	5604387	Plug, cylinder exhaust	4
82a	5603890	Cylinder S250 muffled	1
82b	5608023	Cylinder S250 standard	1
83	5603993	Spud, S250 water inlet	1
84	5604626	Cap, water	1

Item	Part Number	Description	Qty.
85a	5608192	Stem, water threaded	1
85b	5604378	Stem, water barbed	1
86	5603224	O ring	2
87	5602823	Nut, water stem	1
88	5601881	Operating handle nut	1
89	5601343	Washer, lock	1
90	5601887	Operating handle washer	1
91	5604743	Twist grip operating handle	1
92	5603733	O ring	3
93	5601668	Operating handle control body	1
94	5603222	O ring	1
95	5605120	Operating handle adaptor	1
96	5603736	O ring	1
97	5601885	Feed release valve assembly	1
98	5601316	Guard, Stoper handle	1
99	5603262	Chuck nut	1
100	5602440	Cylinder lug liner Stoper	1
101	5605652	Domed nut	1
102	5609822	Chuck	1
103a	5609282	Chuck insert 22mm	1
103b	5604382	Chuck Insert 25mm	1
104	5600770	Gasket, fronthead/cylinder plastic (service only)	1
105	5600769	Gasket, fronthead/cylinder copper (service only)	1
106	5606137	Steel retainer bush	2
107	5609063	Fronthead	1
108	5609107	Steel retainer pin	1
109	5603402	Steel retainer pin nut	1
110a	5600063	Steel retainer 22mm	1
110b	5602663	Steel retainer 25mm	1
111	5602568	Spring	2
112	5604110	Handle guide assembly	1

Item	Part Number	Description	Qty.
113	5603220	Nyloc nut M20	2
114	5602105	Long side rod	2
115	5602027	Washer side nut rod	2
116	5601905	Side rod nut	2
117	5608778	Fronthead lifting handle	1
118	5604374	Handle bar	1
119	5604745	Grip for JH handle	2
120	5602111	Cylinder lug bush	1
121	5601572	Bush backhead lug	1
122	5602916	Nyloc nut 1in UNF	1
123	5601341	Washer for operating handle	1
124	5605010	Bolt, hex	2
125	5602210	Nut, locking jam	2
126	5604384	Spike bottom nut	1
127	5604852	Bottom cap	1
128	5608235	Carrying handle	1
129a	5604848	A/leg cyl 1.30m	1
129b	5604850	A/leg cyl 1.00m	1
129c	5604081	A/leg cyl 0.76m	1
130	5601680	Hat packing dual lip	1
131	5604094	Top cap bush	1
132	5602785	Hat packing single lip	1
133	5607679	Top cap	1
134	5603792	O ring	1
135	5604376	Adaptor nut	1
136a	5605481	Piston rod 1.30m	1
136b	5608785	Piston rod 1.00m	1
136c	5602723	Piston rod 0.76m	1
137	5601773	Upper bucket spacer	1
138a	5603846	Seal, firm Jackleg bucket	2
138b	5604000	Seal, soft Jackleg bucket	2
139	5601774	Lower bucket spacer	1
140	5604024	Washer flat M24	1

Item	Part Number	Description	Qty.
141	5602991	Nut	1
142	5604986	Split pin	1
143	5602891	Bucket spacer upper, steel	1
144	5602890	Spacer, steel	1
145	5602889	Bucket spacer lower, steel	1
146	5608788	Backhead cap	1
147	5603734	O ring	1
148	5604986	split pin	1
149	5601868	Piston rod nut	1
150	5601337	Spring clip	1
151	5601884	Lower bucket spacer stoper	1
152	5603438	Stoper bucket, steel	1
153a	5603851	Seal, firm Stoper bucket	1
153b	5603850	Seal, soft Stoper bucket	1
154	5601883	Upper bucket spacer	1
155	5603439	Upper bucket spacer, steel	1
156a	5608781	Piston rod 0.61 m	1
156b	5608794	Piston rod 0.76 m	1
156c	5602721	Piston rod 0.96m	1
157a	5609331	A/leg cyl stoper 0.61 m	1
157b	5608790	A/leg cyl stoper 0.76 m	1
157c	5602184	A/leg cyl Stoper 0.96 m	1
158	5601907	End cap bush	1
159	5604372	Spike	1